

# Jimmy **SIERRA**



Since  
**1970**



Way of Life!



**SINCE 1970, JIMNY SIERRA HAS GONE WHERE ROADS DON'T!**

# YOU'VE GOT TO BE TOUGH TO SURVIVE OVER 40 YEARS IN THE WILD



Since way back in 1970, the Jimny Sierra has forged a reputation for being tougher than the terrain it has to travel. From the earliest days of the original LJ10 which toughed it out working in the mountains and snow fields of Japan – acclaimed as a working vehicle for forestry and construction industries – to bigger engines, stronger models and more passenger comfort surviving

the toughest terrains around the world; through to today's off-road adventures across the globe. The Jimny Sierra has been a 4WD legend for 4 decades and it still retains its mantle as the 4WD to take you into places the others can't. Because when you need a vehicle to survive in the wild, the Jimny Sierra is tough to beat.



Image from 1974  
LJ50 Brochure

# WE'VE LINED UP THE BEST JIMNY SIERRA YET



## History of Suzuki 4WDs

1970  
LJ10, with air-cooled 260cc engine, is marketed in Japan.

1972  
LJ20, with water-cooled 260cc engine is introduced. Sales outside of Japan start.

1974  
LJ50, with water-cooled 550cc engine is introduced.

1976  
800cc-engine-equipped model, the LJ80, joins the series.

1978  
Total production exceeds the 100,000 mark.

1980  
Total production exceeds the 200,000 mark.

1981  
Full model change for the LJ series, resulting in the SJ series. Introduction of SJ410 with 1,000cc engine.

1982  
Total production exceeds the 300,000 mark.

1984  
The 1,300cc-engine-equipped SJ413 models join the ranks.

1990  
A new 1.3 4-cylinder engine with throttle-body fuel injection was introduced with 49kW.

1998  
A completely redesigned Jimny Sierra offered unprecedented 4WD pleasure on and off the road.

2012  
Jimny Sierra 1.3-litre WT engine 62.5kW of power and 110Nm of torque provides excellent economy.



LJ10



LJ20



LJ50



LJ80



SJ410



SJ413



JIMNY SIERRA

Since 1970, there has been a sensational line-up of Suzuki 4WD vehicles and many milestones along the way.

### 1970

In designing the first Jimny Sierra, the LJ10, Suzuki took a totally different approach to traditional 4WDs. Their philosophy was to build a 4WD that could be equipped for leisure activities and not just a workhorse. This led to the development of the first model, the 260cc LJ10.

### 1972

This was the year that the Jimny Sierra was first marketed to a worldwide audience outside Japan.

### 1974

The LJ50 made its first official Australian debut at the Melbourne Motor Show.

### 1978

The popularity of the Jimny Sierra had grown to the point where 100,000 had been made in this first 8 years. An impressive figure for an off-road 4WD.

### 1981

An important moment in the life of the Jimny Sierra as the first model change was introduced. The resulting SJ410 model had the new base which resulted in the present form of the Jimny Sierra.

### 1984

With the introduction of a four cylinder, water cooled 1300cc engine, this was the time when Suzuki 4WD really began to increase its popularity. This was as much for its off-road fun as for its driving agility and enhanced equipment which made it the ideal multi use vehicle.

### 1988

Calling on its heritage, the sensational new model was named after the traditional Japanese warrior, The Samurai.

### 1998

A completely redesigned Jimny Sierra. A rounded look that contrasted with the edgy lines from earlier models. A newly introduced 4 speed automatic transmission made the Jimny Sierra accessible to a wider range of customers.

### 2012

Over 40 years of a 4WD legend is celebrated. This is the best Jimny Sierra yet, but not the end of the line. Because when you're a legend, the future holds no boundaries.

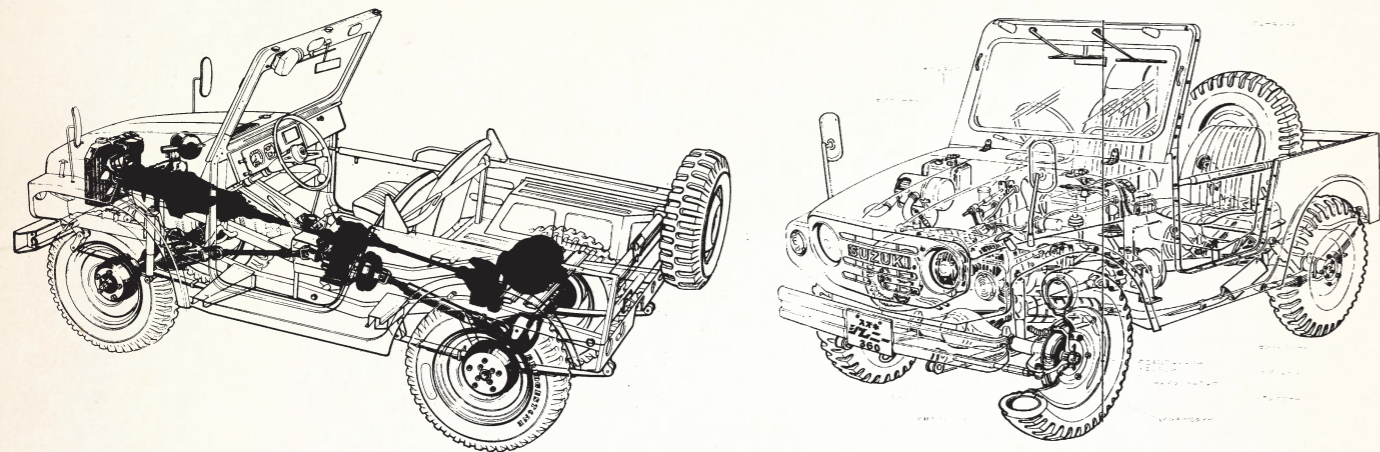

# A 4WD LEGEND OVER 40 YEARS IN THE MAKING

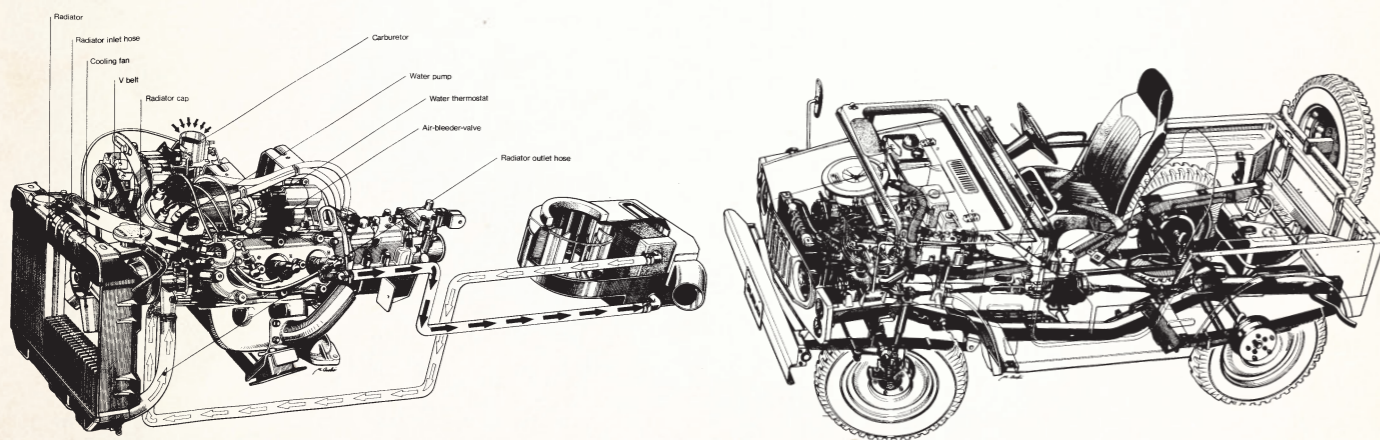

1982  
SJ40



2012  
JIMNY SIERRA

Back in 1970, things were a lot different. Air conditioning meant winding down the windows and power steering meant having strong forearms. Since that time, the legendary Jimny Sierra has travelled many roads in its journey. It is a remarkable

achievement for a remarkable 4WD vehicle as we celebrate this milestone. It may have been over 40 years in the making, but it won't take long to appreciate how special this 4WD legend is.

Since  
1970

Image from 1974  
L150 Brochure

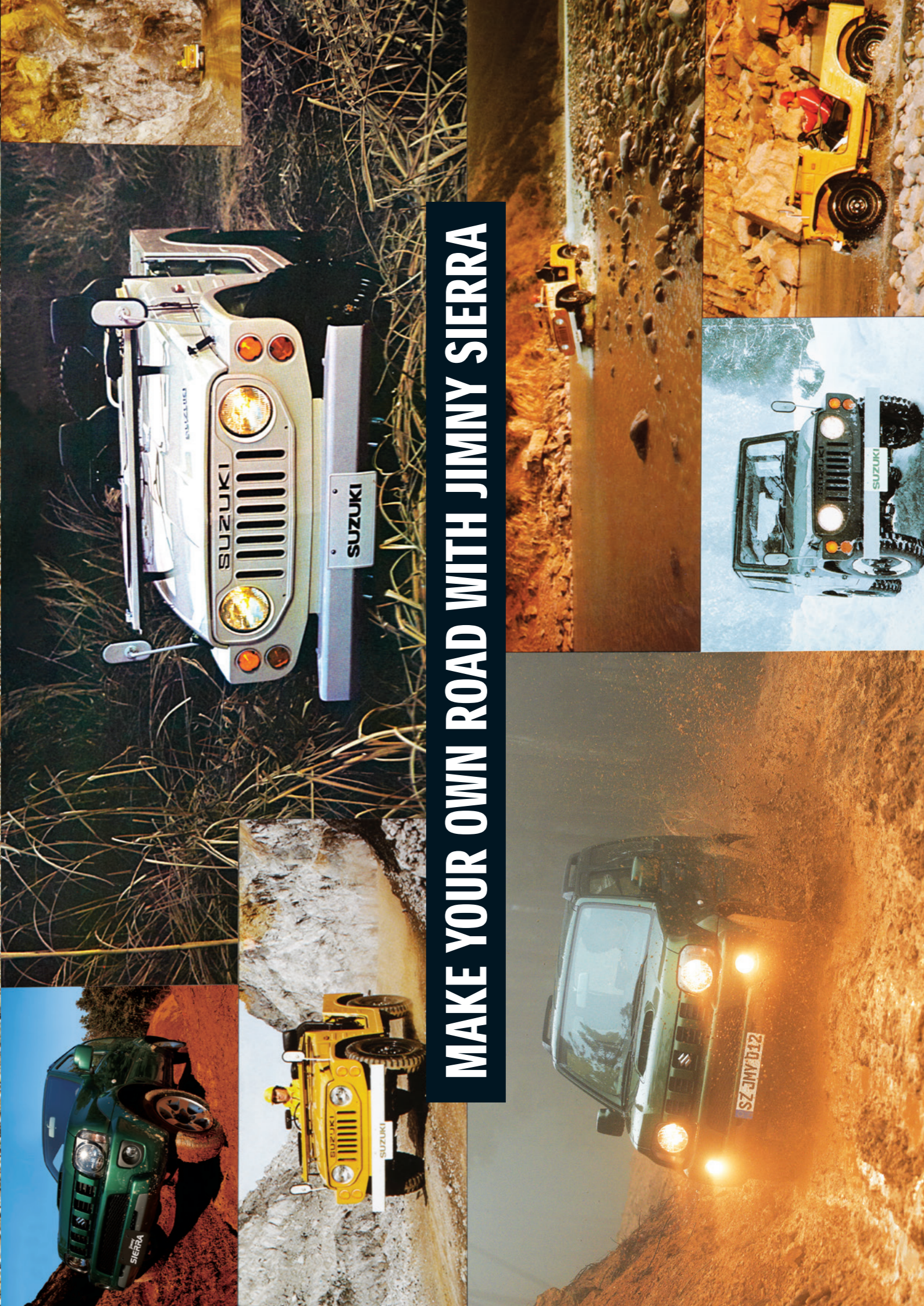

**MAKE YOUR OWN ROAD WITH JIMNY SIERRA**



# BUILT TO LAST



As tough as they were when they were first built, the original Suzuki 4WDs have come a long way. The 2012 version of the original box frame chassis with steel frames is now a sturdy ladder type frame with rigid three-section design giving the Jimny Sierra a solid foundation that stabilises the ride and absorbs shock from the wheels.

Its high performance three link coil suspension handles both highway curves and rocky slopes with assurance. The high performance braking system includes large diameter front disc brakes, an eight inch servo to reduce the effort applied to the brake pedal, and a load-sensing proportioning valve to enhance braking when carrying

a full load. Rigid full-width axles on the current model increase surface contact on uneven terrain and radial tyres and generous approach and departure angles give you extra confidence to climb hills. Safety has come along way too. It is a priority with the Jimny Sierra's body based on Suzuki's proprietary Total Effective Control Technology

(TECT) system. This means that, should an accident occur, the body absorbs impact forces and directs them away from the driver and passengers. For added assurance the Jimny Sierra is equipped with ABS and front airbags to ensure you're built to last too.



Jimny  
**SIERRA**

Since  
1970



# OVER 4 DECADES OF POWER



The original Suzuki 4WDs were powered by a "high performance" 2 stroke/2 cylinder engine with a maximum speed of 50mph. The current model has all the lean muscle you need with a DOCH 1,328 cm<sup>3</sup> 4 cylinder engine. This lightweight all-aluminium powerplant is smooth-revving, fuel efficient and produces plenty of torque for the conditions you most often encounter on roads and dirt. Of course the 4WD system is far more sophisticated 40 years on too. Today you can respond to changing weather and road conditions at a moments notice with its drive action

4WD system which switches on the fly between 4WD and 2WD modes. When in 4WD mode, you can switch between 4WD High for fairly flat surfaces and 4WD Low to negotiate off-road slopes. With such a focus on the environment compared to 1970, the current Jimny Sierra, equipped with four speed automatic or 5 speed manual transmission, keeps its environmental footprint small by delivering gains in fuel efficiency and reductions to emissions through electronic multipoint injection and electronically controlled exhaust gas recirculation.



**EVERYTHING WITHIN EASY DRIVER REACH...**



**... STILL IS OVER 40 YEARS LATER.**



# OVER 40 YEARS OF PUSHING THE BOUNDARIES



## GENUINE SUZUKI ACCESSORIES 40 YEARS ON



Rear upper spoiler    Roof racks    Front mud flap moulded    Rear mud flap moulded    Side steps    Spare wheel cover

Also available: Fog lamps, Headlamp protectors, Weathershields, Bonnet protector, Dust deflector, Flat mud flap, Exhaust tip, Strip load cushion cover, Aerial mounting kit, Bike carrier fork mount, Locking arm, Ski mast holder, and more.

## SPECIFICATIONS

JIMNY SIERRA SPECIFICATIONS	5 SPEED MANUAL	4 SPEED AUTOMATIC	JIMNY SIERRA SPECIFICATIONS	5 SPEED MANUAL	4 SPEED AUTOMATIC
<b>DIMENSIONS</b>			<b>COMFORT</b>		
Overall length	3,675mm		Air conditioning		✓
Overall width	1,600mm		Radio / CD player		✓
Overall height	1,705mm		Power steering		✓
Wheelbase	2,250mm		Power windows		✓
Track	Front	1,355mm	Remote keyless entry		✓
	Rear	1,365mm	Central door locking		✓
Ground clearance	190mm		Electrically adjustable outside mirrors		✓
<b>WEIGHTS</b>			<b>INSTRUMENT PANEL</b>		
Kerb weight (min)	1,060kg	1,075kg	Tachometer		✓
Gross vehicle mass	1,420kg		Trip meter		✓
Towing capacity	braked	1,300kg	Digital clock		✓
	unbraked	350kg			
Tow ball download	75kg		<b>INTERIOR</b>		
<b>ENGINE</b>			Push button 4WD selector		✓
Type	M13A VVT		Interior lights (3 positions)		✓
Number of cylinders	4		Sun visors with vanity mirrors (passenger's side)		✓
Number of valves	16		12 volt accessory socket		✓
Piston displacement	1,328cc		Day / night rear view mirror		✓
Bore stroke	78.0 x 69.5		Sliding and fully reclining front seats		✓
Compression ratio	9.5:1		Adjustable front / rear seat head restraints		✓
Maximum output	62.5kW / 6,000rpm		Walk-in sliding seat system (passenger side)		✓
Maximum torque	110Nm / 4,100rpm		Reclining and folding rear seats		✓
Fuel distribution	Multipoint injection		Moulded, cloth accented door trim		✓
<b>FUEL CONSUMPTION</b>			Moulded rear quarter trim with pocket / cup holder		✓
Combined	7.1 L/100km*	7.4 L/100km*	Door pockets		✓
CO <sub>2</sub> emissions	168 g/km		Centre console with cup holder		✓
		175 g/km	Internal fuel lid opener		✓
<b>TRANSMISSION</b>			<b>SAFETY AND SECURITY</b>		
Gear ratio	1st	4.425	Driver & Passenger front SRS airbags		✓
	2nd	2.304	3-point ELR seat belts (x4)		✓
	3rd	1.674	Height adjustable front seat belt anchorage		✓
	4th	1.190	Side impact protection beams		✓
	5th	1.000	Engine immobiliser		✓
	Reverse	5.151	ABS		✓
Final gear ratio	4.300		<b>EXTERIOR</b>		
Transfer	High	1.000	Halogen headlights		✓
	Low	2.002	2 speed intermittent front wiper		✓
<b>CHASSIS</b>			Intermittent rear wiper and washer		✓
Brakes	Front	Discs	Rear window demister		✓
	Rear	Drums	Green tinted glass window		✓
Suspension	Front	3-Link rigid with coil spring	Coloured bumper / body side moulding		✓
	Rear	3-Link rigid with coil spring	Alloy wheels		OPT
Tyres	205 / 70R15		Roof rails		✓
Minimum turning radius	4.9m		Free wheel hubs (vacuum hubs)		✓
Seating capacity	4				
Fuel tank capacity	40L				

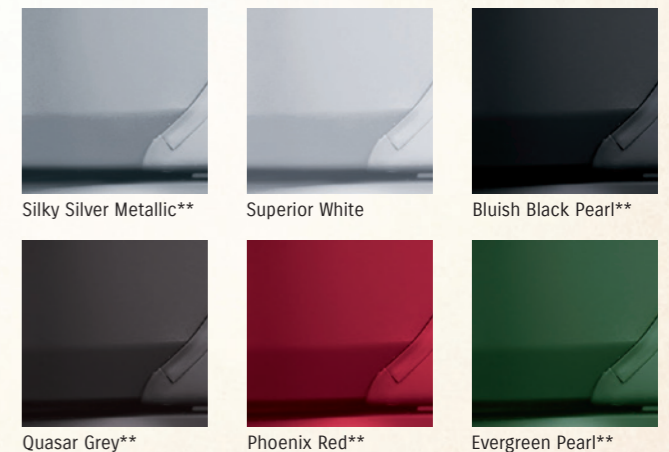
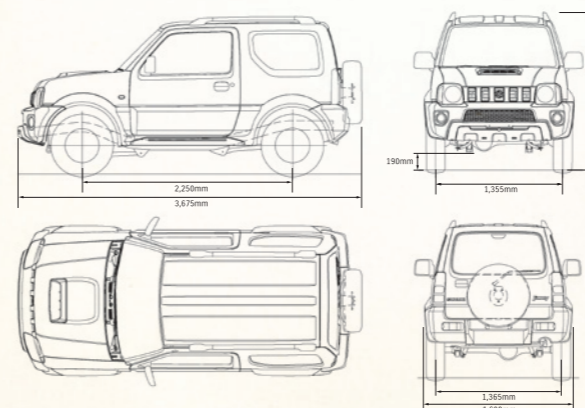

\*ADR81/01 test results. \*\*Additional premium/metallic paint charge. Colours are subject to availability.

1970



1980



1990



2000



2012



All care is taken to ensure the accuracy of this brochure at the time of publication approval. Specifications, features, prices and model availability may vary from State to State and may change without notice. Always consult your authorised Suzuki Dealer or refer to [www.suzuki.com.au](http://www.suzuki.com.au) for the latest details on all models. SUZUKI AUSTRALIA will not be held liable for any loss as a result of reliance on the content of this brochure, whether in negligence or otherwise. Vehicles are shown for illustrative purposes only and may not depict exact Australian specifications. Published July 2012. TSPSUZ1339

[www.suzuki.com.au](http://www.suzuki.com.au)



Way of Life!