

1985

Ford Escort

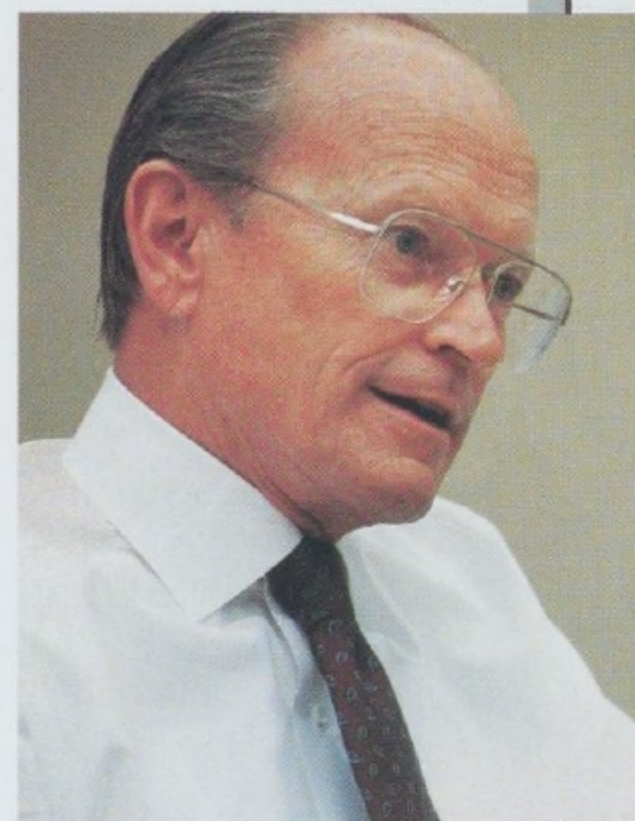



Donald E. Petersen  
President



Ford Motor Company  
The American Road  
Dearborn, Michigan 48121

Dear New Car Buyer:

Quality is Job 1 at Ford Motor Company. This isn't just a phrase. It's a commitment to total quality.

Total quality begins with the design and engineering of our cars and continues through the life of the product. We plan them with a vision of the customer — of you — sitting behind the wheel of a new car.

Total quality will be apparent to you through functional performance, overall vehicle integrity, the "look and feel" of materials, satisfying aesthetics, safety, serviceability and cost of ownership.

Total quality requires continuous improvement in everything we do. Every employee at Ford Motor Company is involved in the process of meeting your needs and expectations.

I think the 1985 Escort is an excellent example of the quality I'm talking about. Escort is a well-equipped small car that delivers solid value. It's a fun car to drive and has the kinds of features that make it a pleasure to own.

I invite you to look over our new 1985 Ford cars in your dealer's showroom. Test drive them on the road. When you do, I think you'll understand all that's involved in the total quality concept at Ford Motor Company.

Donald E. Petersen  
President  
Ford Motor Company

## Ford Escort for 1985

Escort is Ford's most popular fun-to-drive small car. It's economical to operate and is equipped with features that make it a delight to drive day after day. Escort also gives you a wide choice of 2-door, 4-door and wagon models in luxury and sport models.

### Contents

Quality and Workmanship . . . .	4-5
Ride and Handling . . . . .	6-7
Power and Efficiency . . . . .	8-9
Ford Escort Environment . . . .	10-11
Ford Escort LX . . . . .	12-13
Escort GL . . . . .	14-15
Ford Escort L . . . . .	16-17
Ford Escort GT and Turbo GT . . . . .	18-19
Features, Options, Colors and Trims . . . . .	20-21
Safety Features . . . . .	22
Owner Information . . . . .	23



**Escort LX** is built in the European touring sedan tradition, combining luxurious interior appointments with total performance capability. Available in 4-door hatchback and wagon models.



**Escort GL** stands at the center of the model line-up with emphasis on comfort and convenience. Available in 2- and 4-door hatchback and wagon models.



**Escort and Escort L** series feature a high level of standard equipment in a fun-to-drive small car. Available in 2-door and 4-door hatchback and wagon models.



**Escort GT and Turbo GT** models provide the ultimate in Escort driving excitement. They combine excellent balance with responsive performance. Available in 2-door hatchback models.

Front and back covers: Escort GL 4-door.  
Some equipment shown may be optional.

**A word about this catalog:** Some of the equipment shown or described throughout the catalog is available at extra cost.

# Quality and Workmanship

Ford Motor Company is committed to building cars that meet the high quality standards expected by those who drive them.

Every aspect of the car's design has a purpose, whether it be aerodynamic efficiency or interior comfort.

Engineering systems — the engine and suspension, for example — are manufactured and assembled under strict quality controls.

The hood, doors, decklid, moldings — everything has stringent fit tolerances. The paint finish is smooth and lustrous.

Behind the quality of every Ford car are the dedicated people who produce it.

## **Design and engineering, where quality begins.**

Quality demands that before a car can be built right, it must first be designed and engineered right.



Today, engineers can measure with amazing accuracy how a car responds to actual on-road conditions long before it is built. It's done with simulations of full-scale vehicles and individual components in action on computer screens.

Vehicles can be driven around pylons at various speeds, climb steep grades, run over potholes, just as they would be in real testing at a proving ground. The computer displays in close detail the intricate movements of the suspension and other systems. They're evaluated to high standards of performance, redesigned and retested if necessary.

Even with this advanced technology, however, the art of automotive design and engineering remains in the hands of designers and engineers. The computer is there to assist them.

## **Withstanding stress. The ultimate test of a car's quality.**

Drivers expect their cars to function properly in everyday use. So Ford cars are road-tested over hundreds of thousands of miles, are subjected to extreme stress and load conditions over paved and unpaved surfaces, up and down steep grades, through corrosive salt baths. They run the full course of demanding acceleration, cornering and braking maneuvers.

But even before these road tests, Ford engineers put prototype cars through numerous laboratory tests. The Electrodynamic Actuator, for example, drives a car continuously under a variety of road and weather conditions. One objective is to eliminate squeaks and rattles caused by bumps and jolts and the effects of hot and cold temperatures.



Left: Escort GL 4-door. Some equipment shown may be optional.



## **Computers, robots and lasers in manufacturing and assembly.**

Monitoring engine performance, checking electrical systems for accuracy, helping ensure smooth paint applications for finish quality — these are some of the vital roles that computers play in the assembly of Ford cars.

Ford places great importance also on robotics to achieve high quality in fit, finish and function. Robots are programmed to provide consistency and control to an extraordinary degree. They can do the 2,000 welds on a car's body quickly, completely, with the precision the blueprints demand.

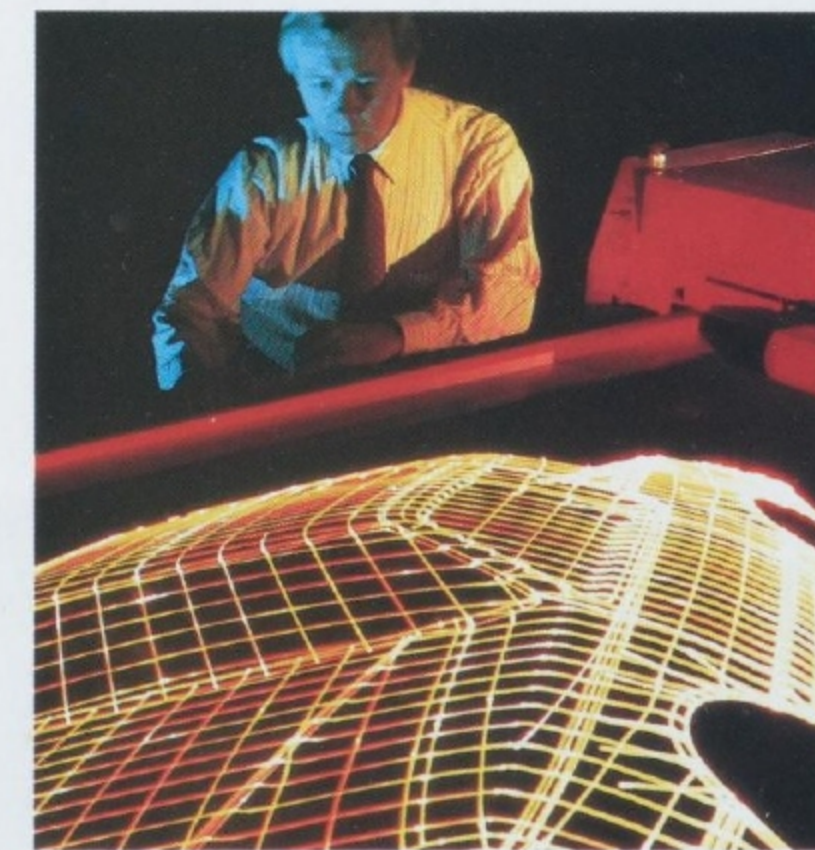

The laser, another advanced-technology tool, helps improve quality by providing accurate measurement of everything from engine castings and door margins to nuts and bolts and fasteners.

## **Special quality steps: Corrosion protection.**

Ford takes tough measures to protect its cars against the damaging effects of corrosion. Galvanized steel is used for important underbody and structural parts. Pre-coated steel, featuring corrosion inhibitors, is also used in major body panels. Special treatments are applied to selected areas of the body structure.

## **Ingenuity and teamwork. The essential ingredients of high quality.**

At Ford, striving for high quality is a team effort. This is nowhere more evident than in the hundreds of recommendations for quality improvements submitted every year by more than 1,100 Employee Involvement (EI) groups in 65 Ford plants across America.

In addition to the EI groups, there are "durability-reliability" teams specially trained to carry out extensive quality control programs before production begins, and "quality" teams whose primary responsibility is quality improvement after production gets under way.



With all the technology and resources at work producing quality products, the people at Ford realize that quality is a never-ending preoccupation. This attitude is essential to Ford's total commitment to quality.

# Ride and Handling

Escort's smooth ride and excellent handling characteristics are the direct result of its four-wheel, fully independent suspension system.

## Independent rear suspension (IRS)

The completely independent rear suspension system of the 1985 Escort helps provide ride qualities typically associated with larger cars.

The transverse suspension arms (1), galvanized for corrosion resistance, and the tie rods (2), control lateral and longitudinal wheel movements.

Compliant rubber bushings are used at all attachment points to reduce the effects of road shock transmitted to the body, and to help minimize noise transfer to the passenger compartment. And because there is no solid rear axle, unsprung weight at each wheel is reduced, improving ride and handling over rough surfaces.

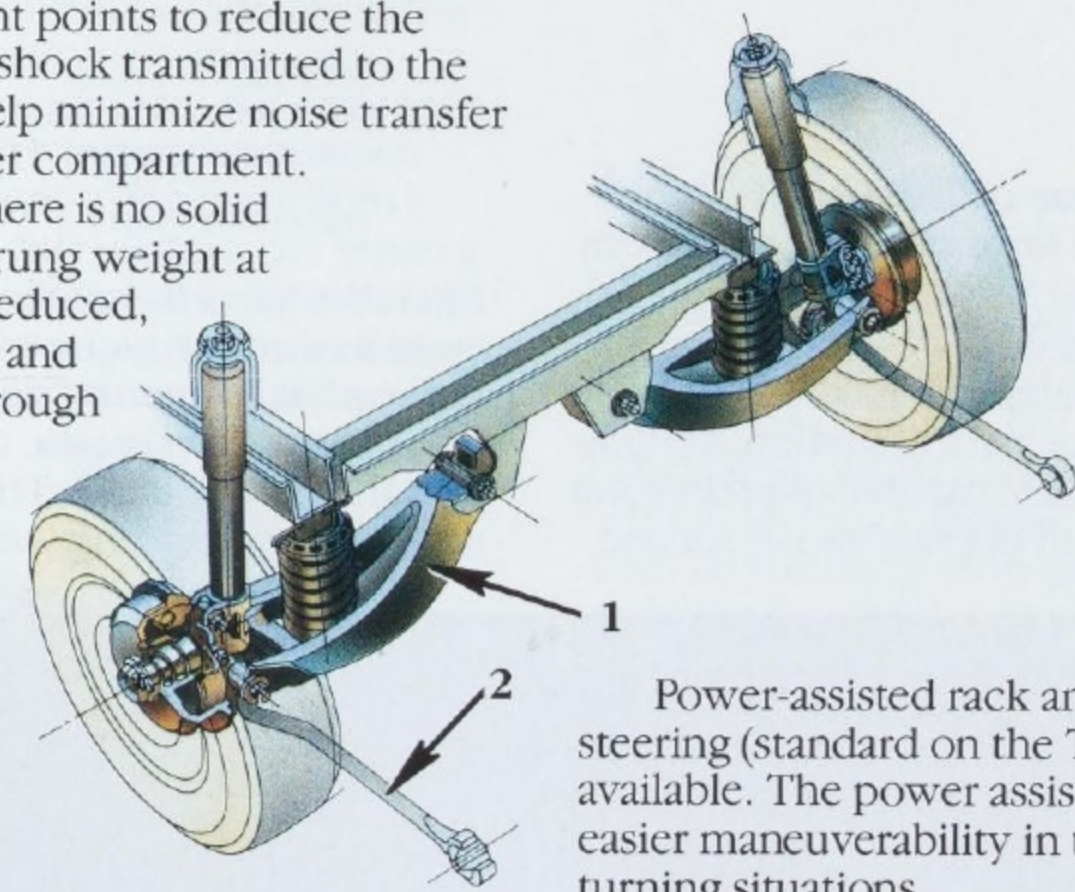

Power-assisted rack and pinion steering (standard on the Turbo GT) is available. The power assist provides easier maneuverability in tight parking or turning situations.

car to a smooth, even stop. The proportioning valves compensate for dynamic weight transfer during braking and vary hydraulic pressure to the brakes accordingly.

## Reduced rolling resistance steel-belted radial tires

Rolling resistance affects fuel economy. By optimizing tread design, tire body compounds, reducing tire weight and increasing tire pressure, rolling resistance can be substantially reduced for an overall improvement in fuel economy\* and handling.



## Airflow as a stabilizing force

Escort's aerodynamic shape does more than help the engine deliver excellent fuel economy. The steering and suspension systems benefit as well. Through careful fine-tuning of selected design areas, airflow is directed to reduce front and rear lift for directional stability, and cornering agility.

\*See Gas mileage on page 9.



## MacPherson strut front suspension

The MacPherson design front suspension uses "zero or nominal scrub" geometry to assist in front wheel tracking. In zero scrub geometry, the strut (3) pivot axis intersects the road at the same point as the tire centerline.

The front suspension includes a stabilizer bar (4), linking the left and right forged lower suspension arms (5), to control body roll in tight turns.

## Rack and pinion steering

The responsiveness of the Escort's rack and pinion steering is directly related to its simple, low friction design.

At the end of the steering column is a "pinion gear" (6), which engages a

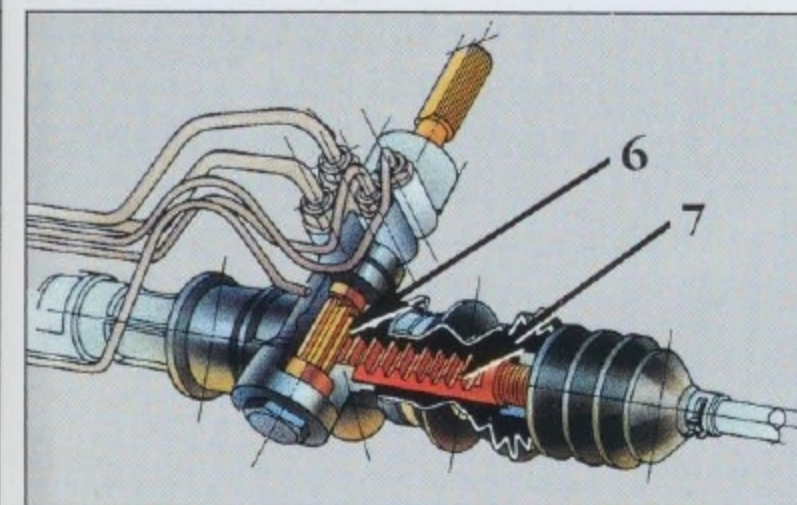

"rack" (7), of gear teeth linked to the steering arms. Turning the steering wheel rotates the pinion gear and moves the rack laterally.

The result is a firm, precise feel which adds to Escort's fun-to-drive qualities.

## Split diagonal service braking system

Escort's braking system has three major features: front disc/rear drum brakes; split diagonal service and proportioning valves in the master cylinder. The front discs are the "pin-slider" type designed to reduce brake drag. The split service hydraulic system connects the right front brake to the left rear brake and the left front brake to the right rear brake. Should one system fail, the other can bring the

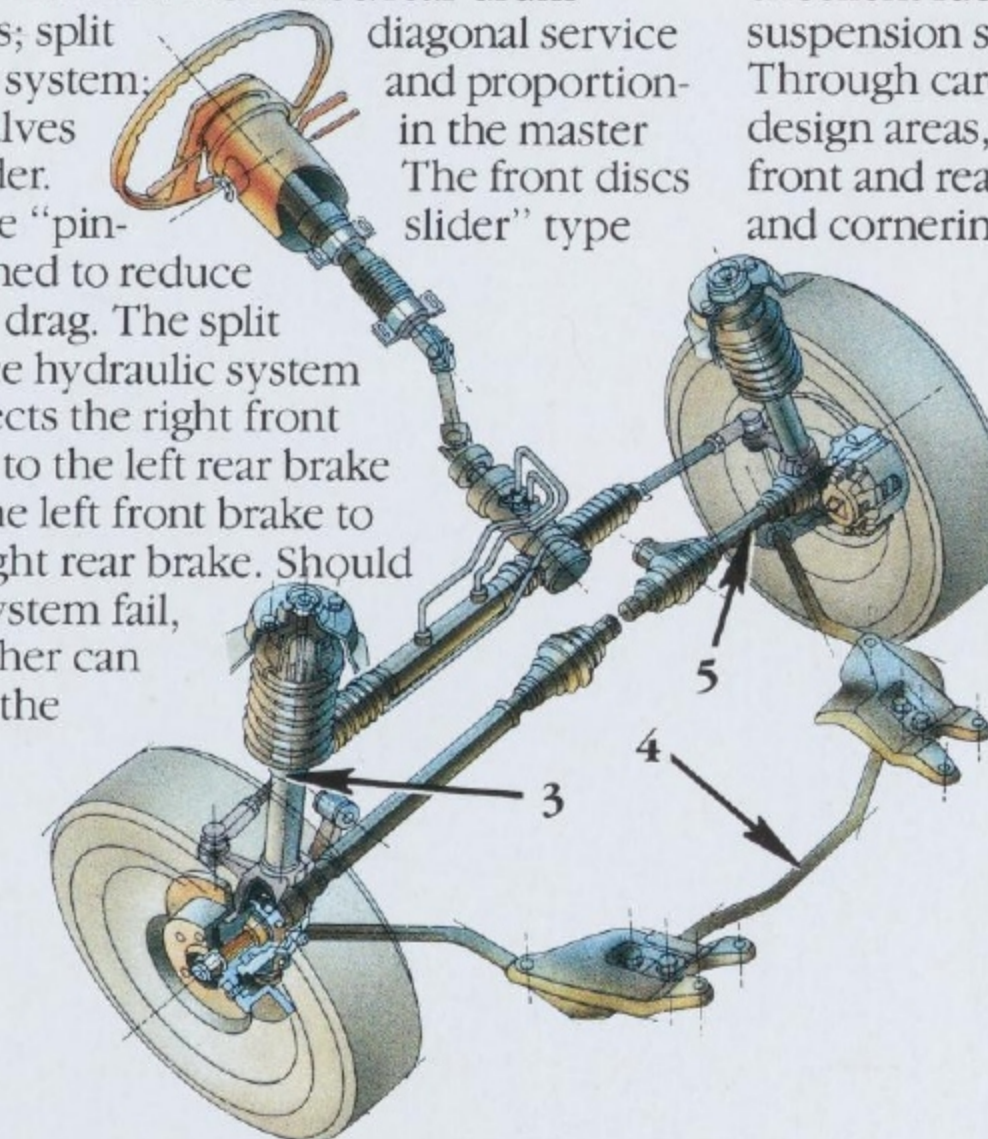

Left: Escort GT shown with optional rear window defroster, TR-type aluminum wheels.

# Power and Efficiency

## EEC-IV: one of the world's most advanced automotive computers

The EEC-IV computer control module (used on 1.6L EFI and turbo engines) is a fourth generation, state-of-the-art, microprocessor-based engine control system capable of processing thousands of operations per second.

Ford's EEC-IV computer provides precise and instantaneous control over vital engine functions.

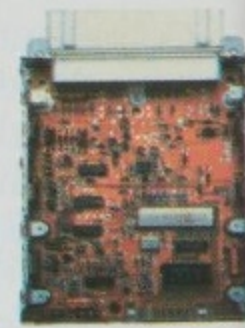

EEC-IV adjusts the air/fuel mixture and ignition timing for quick cold starts. On the road, it constantly senses what the car is being asked to do, then balances the air/fuel mixture and timing for optimum power, response and efficiency.

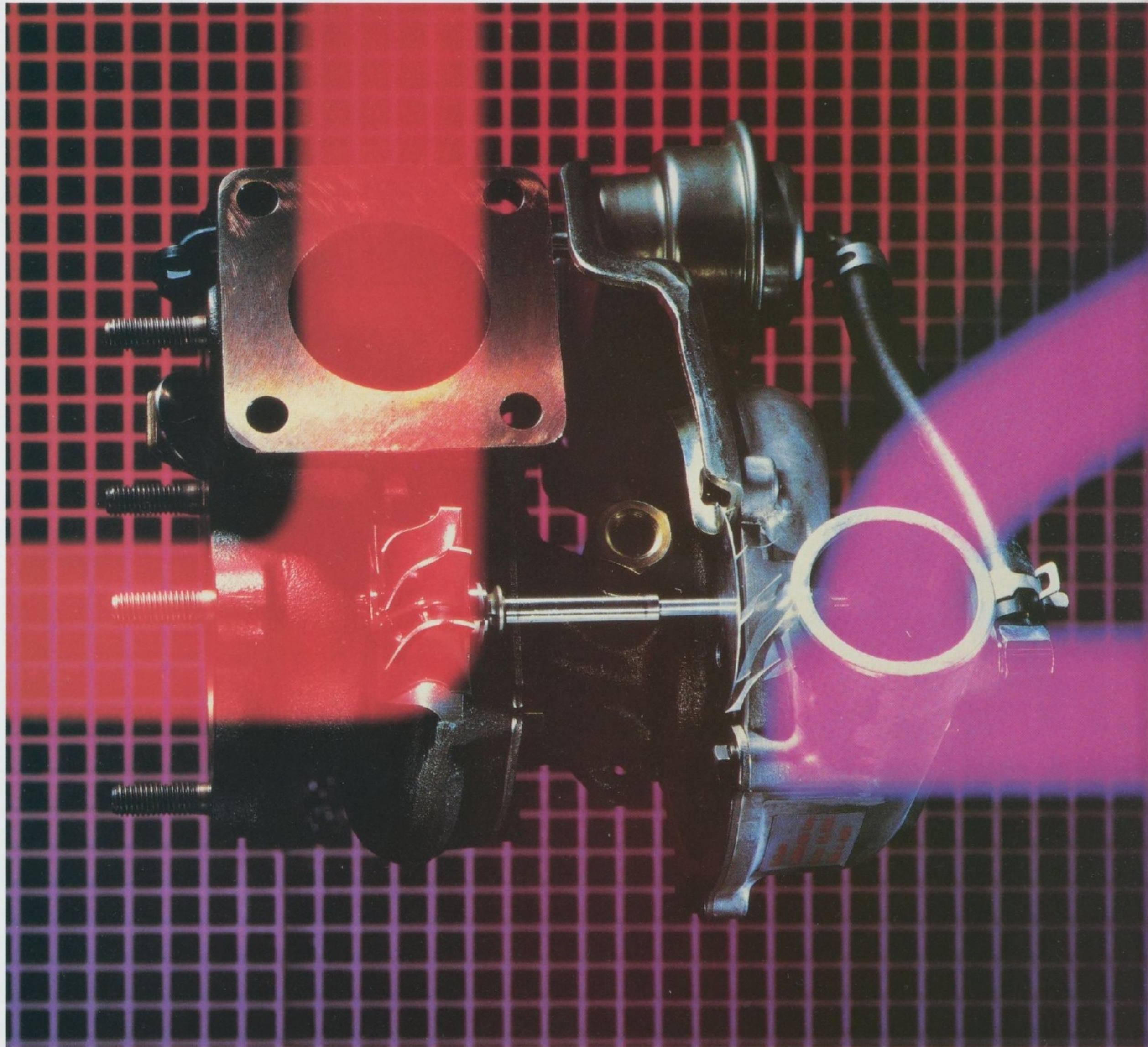

## Turbocharging: efficient power

Turbocharging is one answer to the challenge of obtaining power *and* efficiency. It provides two major benefits; under normal driving circumstances, the turbo efficiently remains inactive, contributing to fuel savings. But when a surge of power is required, for instance when passing, pressing down on the accelerator brings the turbo into action.

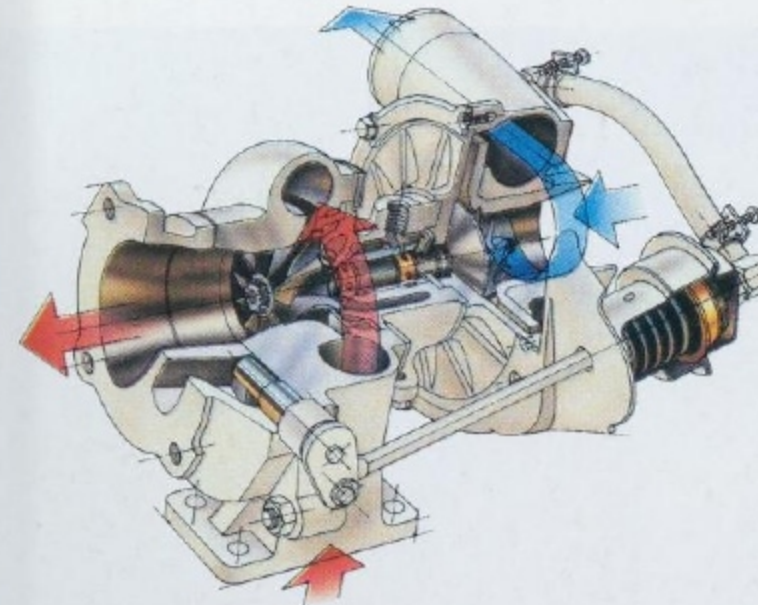

Turbocharging: Hot exhaust gases (red) turn the turbine wheel to power the compressor. Outside ambient air (blue) enters the compressor and is blown through the induction system to the combustion chambers.

## Escort powerteams

Engine	Transaxle	Final Drive Ratio		
		49 States	High Altitude	Calif.
1.6L 2V FS*	4-spd. manual with overdrive fourth gear	3.04	—	—
1.6L 2V	4-spd. manual with overdrive fourth gear	3.59	—	3.59
1.6L 2V HO	5-spd. manual	3.73	3.73	3.73
1.6L 2V HO	ATX	3.31	3.31	3.31
1.6L EFI	5-spd. manual	3.73	3.73	3.73
1.6L EFI	ATX	3.31	3.31	3.31
1.6L EFI Turbo	5-spd. manual	3.73	3.73	3.73
2.0L Diesel FS*	5-spd. manual	3.52	3.52	—
2.0L Diesel	5-spd. manual	3.52	3.52	3.52

\*Certain equipment model restrictions apply. See your dealer for specific information. Upshift indicator light included in some applications.

## Turbocharged power: Escort Turbo GT

The Turbo GT's engine is an efficient, high-performance, crossflow head, overhead cam four-cylinder engine. It displaces 1.6 liters and has a compression ratio of 8.0 to 1. It has five main bearings, forged aluminum pistons, high-temperature alloy valves, oil cooler and tuned intake manifold. The port-type fuel injection system, fed by an electric fuel pump, injects a precisely controlled amount of fuel into the intake port just ahead of the intake valve. A "blow-through" turbocharger is positioned upstream from the injectors and throttle plate. Unlike "draw-through" turbocharging arrangements, a "blow-through" system minimizes lag time delivering crisp, quick throttle response.

## 2.0L diesel engine

Escort diesel models are equipped with a true diesel, not a converted gasoline engine. Because it was designed as a diesel from the outset, a number of innovations were built in. For instance, the cold start problem normally associated with most diesel engines was eliminated with an advanced glow plug system that provides 3-second wait-to-start capability at 0° F.

To separate water from the diesel fuel, a condition common to all diesels, Escort's 2.0L diesel includes a fine filtration water separator, flashing water level warning light on the instrument panel, and an easily accessible water drain for fast "do-it-yourself" draining. There's also a standard automatic fuel heater to prevent cold weather fuel waxing.

The L and GL diesel models also include added sound insulation, tachometer, trip odometer and temperature gauge. And Escort's already high mileage ratings are even higher with the diesel.

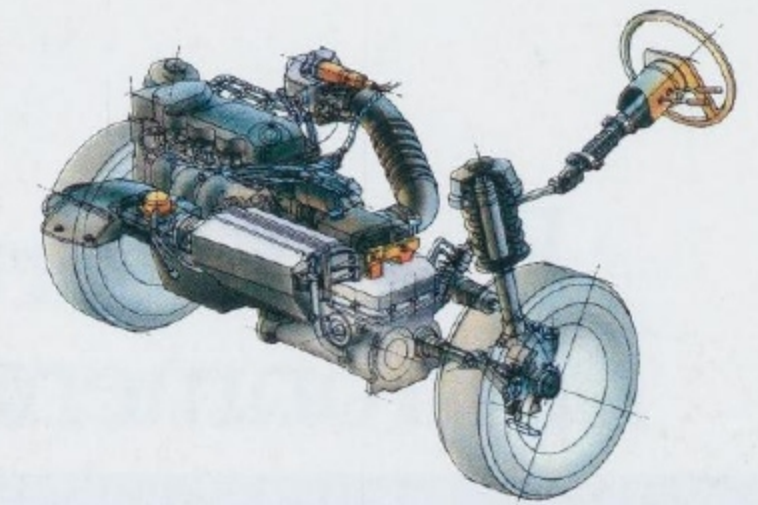

## 1.6L electronically fuel-injected engine

Electronic fuel injection (EFI) provides important advantages over a conventional carburetor, but the major advantage is the more efficient use of fuel. High pressure discharge from the fuel injectors also improves fuel distribution.

EFI improves overall operation. It is smooth running and provides easy starting in temperature extremes. The EFI system on Escort GT and LX models is the port type, which means that fuel is injected near each cylinder intake port. This assures that the fuel spray is evenly dispersed in the air drawn into the cylinder, maximizing the combustion process.

## 1.6L HO and 1.6L compound valve hemispherical head (CVH) engines

Escort's high mileage powerplants take advantage of hemispherically designed combustion chambers for high fuel efficiency and low exhaust emissions. By utilizing hemispherically shaped combustion chambers in the cylinder heads and domed piston crowns, the fuel/air mixture is forced to the center of the combustion chambers resulting in a more complete burn, less fuel waste and more power. Additionally, the spark plugs are placed near the center of the domed cylinder heads for efficient combustion.

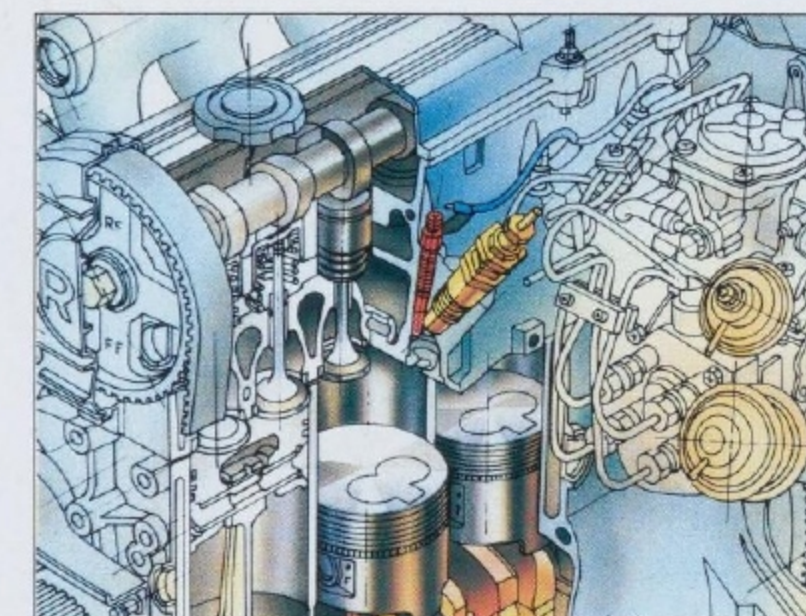

## Gas mileage

1985 EPA mileage estimates were not available at the time this catalog was approved for printing. As soon as EPA figures are released, your Ford Dealer will be among the first to receive this information and will be happy to pass it along to you.

# Ford Escort Environment

While the driver's main concern is staying alert to the changing conditions around him and controlling the vehicle, his passengers should only have to concentrate on being comfortable. In Escort's interior, the needs of both are well looked after.

## Room and comfort for four

Escort's roomy interior provides comfortable room for four passengers with the added convenience of a versatile passenger/cargo area.

Escort's body-contoured front bucket seats combine foam padding over a spring steel base with the warmth of cloth and the individual comfort of reclining seat backs.

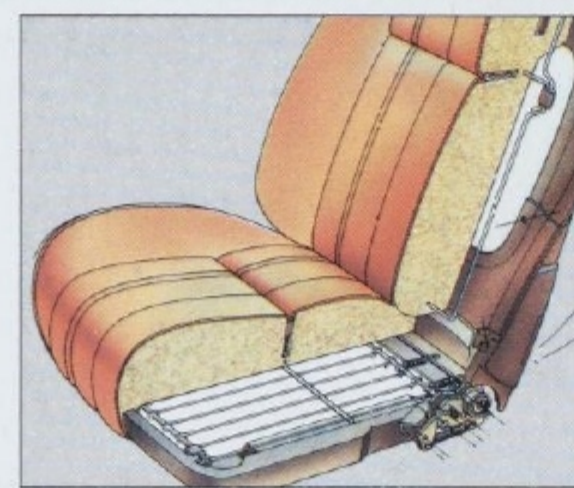
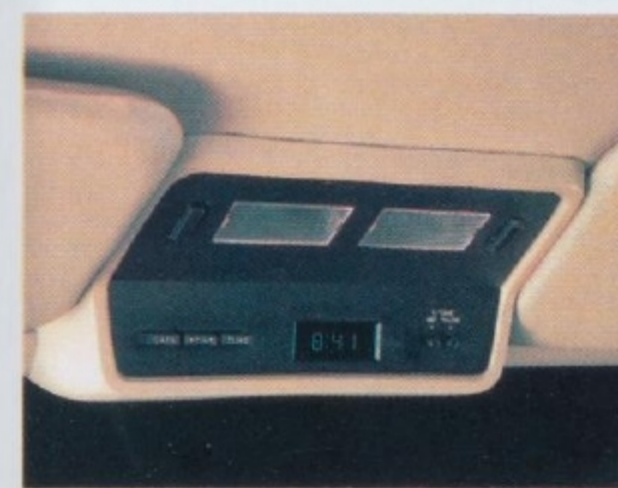

## Ergonomics and Escort's driver command center

Ergonomics, simply defined, is the close relationship of the driver to the car. In the Escort that relationship has been carefully developed to provide the best possible driving positions and to conveniently locate all controls. Instruments and warning lights are designed for optimum visibility and clarity. The driver-biased instrument panel is curved to angle controls and instruments toward the driver. And the driver seat track provides more than seven inches of travel to help the driver assume his or her most comfortable position at the wheel.

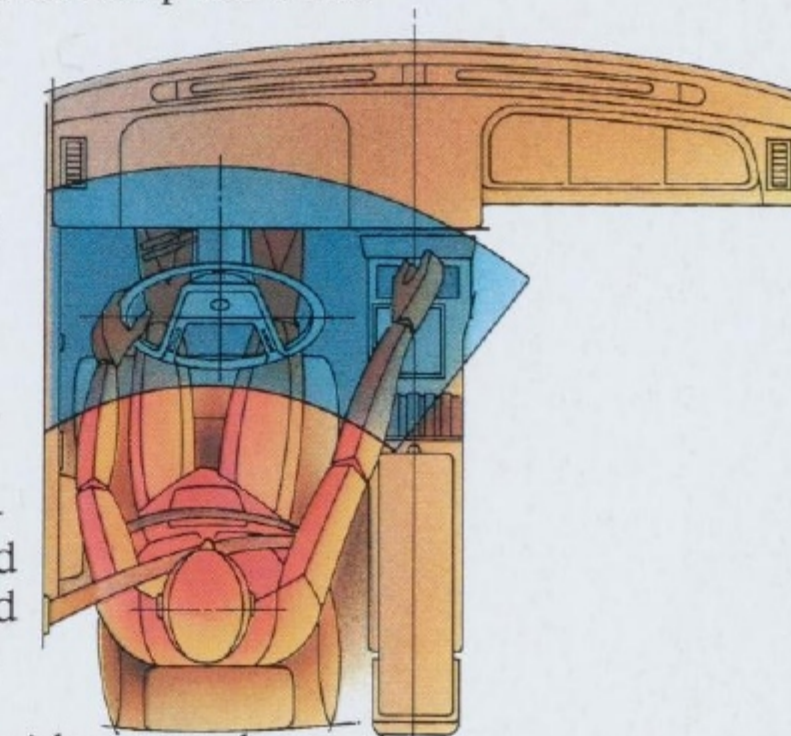

## Variable passenger/cargo area

Another attribute of Escort interior design is versatility. With the rear seat up, the Escort provides room for four with more than 17 cu. ft. of cargo space. Fold down the rear seat and there's room for 37 cu. ft. of cargo. Escort Wagons let you carry as much as 58 cu. ft. of cargo. GL, LX, GT and Turbo GT have even more versatility with a dual/fold split rear seat. Fold one seat back down for long cargo and you still have room for a rear passenger. Or fold both seat backs down when maximum load space is required.



Top left: Digital clock and overhead console standard in LX, GT, Turbo GT.

Center and bottom left: Escort LX interior shown with optional automatic transaxle, air conditioning, AM/FM stereo radio, speed control, power door locks, rear window defroster and interval wipers.

# Ford Escort LX

Escort LX is designed and built in the image of a proper touring automobile.

It's equipped with a special TR Performance Suspension system. TR-type styled steel wheels and Michelin TRX tires. The responsive and efficient\* 1.6L electronically port fuel-injected 4-cylinder engine and 5-speed manual transaxle provide the power.

The interior includes numerous comfort and convenience items designed to enhance your driving enjoyment. Features such as low-back reclining bucket seats. A dual/fold split rear seat. Center console with graphic display warning module. AM radio with dual front speakers.\*\* Remote locking fuel door. Remote liftgate release. Digital clock with overhead console, courtesy and map lights.



Outside Escort LX is treated to special blackout accents and tape striping. Bright front and rear bumpers with rub-strips and guards also help set LX apart.

\*See Gas mileage on page 9.  
\*\*May be deleted for credit.



Left: Escort LX 4-door shown with optional pivoting front vent windows and rear window wiper/washer.

# Ford Escort GL

Escort GL shares a number of fine Escort features with the top-of-the-line LX. For instance, in GL you get low-back reclining front bucket seats and convenient dual/fold split rear bench seat. GL carpeting is color-keyed throughout the

interior and extends into the cargo area including the fold down seat backs. The door trim panels incorporate handy storage bins in their lower carpeted sections.

There are many additional convenience items, too, that you ordinarily wouldn't expect to find on a car in GL's price range. Remote locking fuel door. Remote liftgate release. AM radio with dual front speakers,\* to name a few.



Escort GL is very economical\*\* to operate as well, with the standard 1.6L CVH 4-cylinder engine and 4-speed manual transaxle and its overdrive fourth gear.

You can also order the Escort GL in a diesel model or the Escort GL with the optional "FS" gas engine for the optimum in fuel economy.

\*May be deleted for credit.  
\*\*See Gas mileage on page 9.



*Left: Escort GL 4-door shown with optional styled steel wheels and bright trim rings, front and rear bumper guards, rear window wiper washer, rear window defroster, dual remote control racing mirrors and pivoting front vent windows.*



# Ford Escort

# L

Escort L and the standard Escort set high levels of value and quality that the competition is hard put to match. And

they have all the standard features that have made Escort a best seller year after year. Front-wheel drive. Rack and pinion steering. Four-wheel independent suspension. And much more.



To see just how well-equipped a subcompact can be, take a look at the list of standard equipment on page 21. Use it for comparison with other subcompacts. You'll see why so many people have chosen Escort.

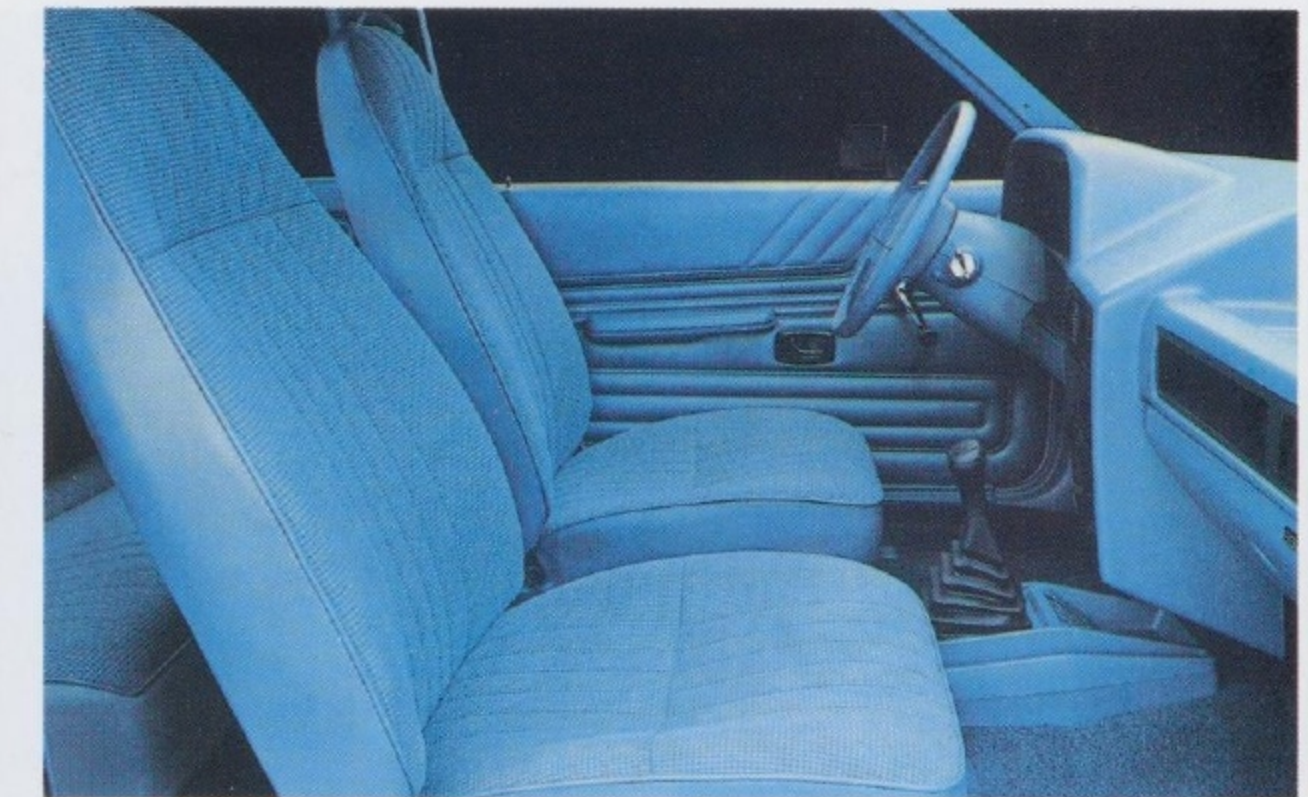

Left: Escort L 2-door

# Ford Escort GT and Turbo GT

The Escort GT is equipped with 1.6L fuel-injected 4-cylinder engine, sport-tuned exhaust and 5-speed transaxle. TR performance suspension components,

rack and pinion steering (power-assisted on Turbo GT), power front disc/rear drum brakes and Michelin TRX tires put you in control of the road.

The performance aspect is carried over into the interior as well, with Sport Performance front bucket seats and dual/fold split bench in the rear, both with cloth trim.



Escort Turbo GT adds its own style of driving fun with its turbocharged electronic fuel injected 4-cylinder engine and 5-speed manual transaxle.

Both GT and Turbo GT also include numerous other features that are spelled out completely on page 21.



*Left: Escort Turbo GT shown with optional TR-type aluminum wheels, electric rear-window defroster and flip up open air roof.*

# Ford Escort Features and Options

## Rapid-Spec Packages — the best way to buy Ford Escort options.

When you select your new Escort, be sure to ask your Ford Dealer about Rapid-Spec Packages. They benefit you in these two important ways: (1) They simplify the ordering procedure and (2) they can save you money. Many packages include Value Option Discounts. These can represent savings over the manufacturer's suggested retail price totals of the same options if purchased separately. Your dealer has complete details.

## Electronic AM/FM stereo search radio/cassette player

Some of the features of this state-of-the-art quality sound system are: Dolby® Noise Reduction; seek tuning that selects the next listenable station either up or down scale; scan tuning that auditions stations for 8 seconds; and a "music search" feature that locates the beginning of the next or previous song on the cassette tape.

## Graphic equalizer

Ford Escort's optional graphic equalizer features 7-band tone control for precise sound mixing over a wide frequency range.

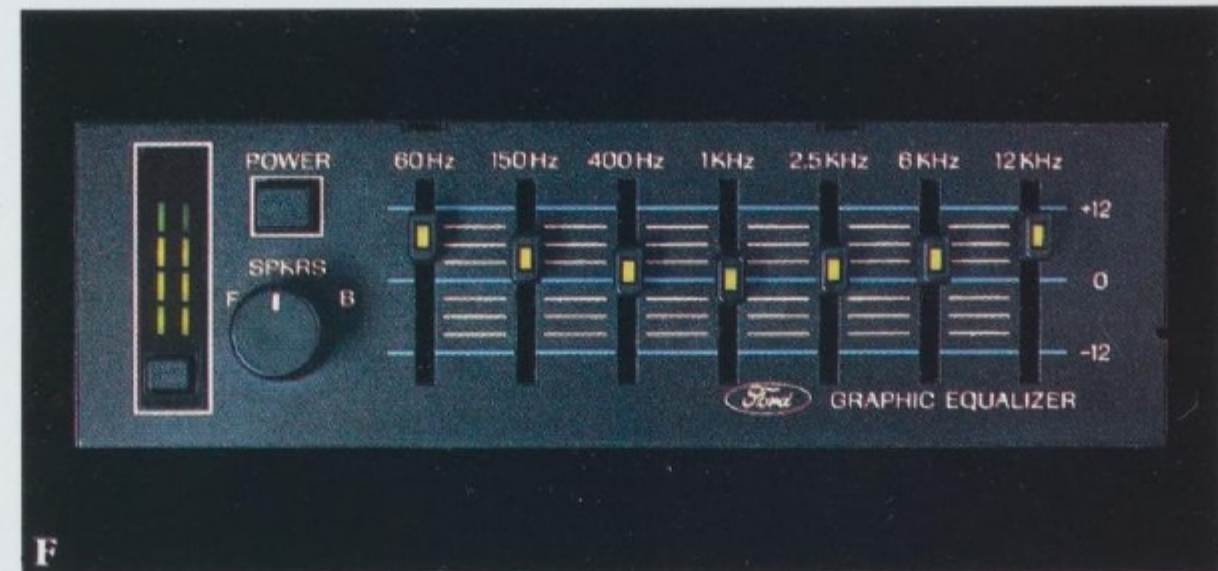
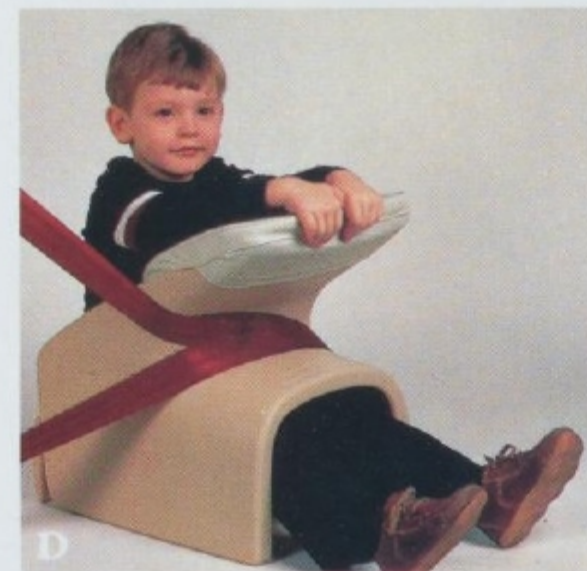
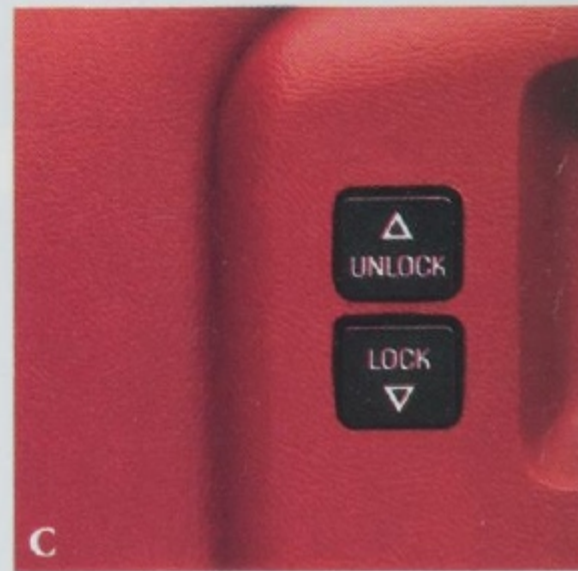

## Illustrated options

(A) Center Console; (B) Pivoting Front Vent Windows; (C) Power Locks; (D) Tot-Guard for children 20 to 50 pounds (available at Ford Dealers); (E) Electronic AM/FM Stereo Search Radio with Cassette Player; (F) Graphic Equalizer; (G) Rear Window Wiper/Washer; (H) TR-Type Aluminum Wheels; (I) Styled Steel Wheels with Bright Trim Rings.

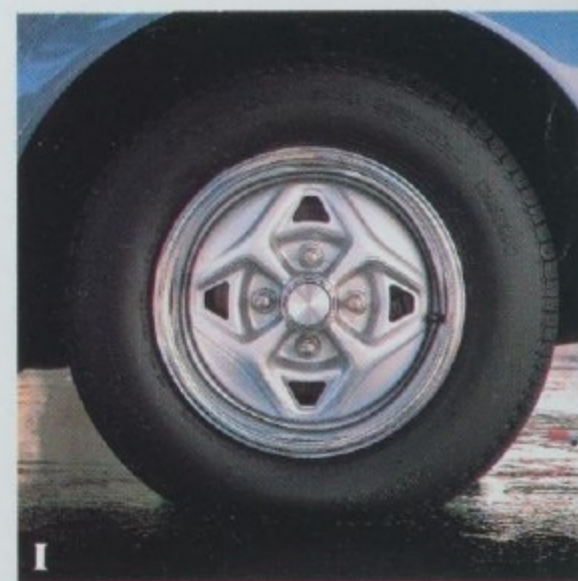
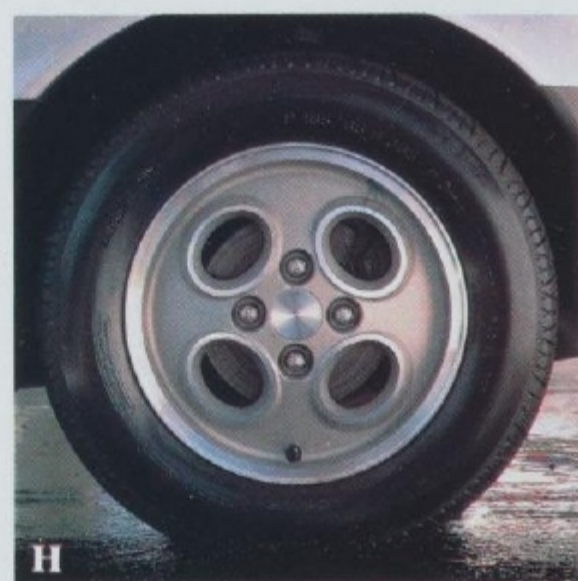

## A word about Ford options

Some of the equipment shown or described throughout the catalog is available at extra cost.

## FORD ESCORT FEATURES

ENGINEERING	Escort(4)	L	GL	LX	GT(5)	GT(5)	Turbo
Front-wheel drive	S	S	S	S	S	S	S
Four-wheel independent suspension with MacPherson strut front system and stabilizer bar, transverse lower suspension arms and fore and aft tie rods — with coil springs	S	S	S	S	S	S	S
1.6L CVH "FS" engine (1)	S	O	O	NA	NA	NA	NA
1.6 liter CVH engine (1)	S	S	S	NA	NA	NA	NA
1.6 liter EFI engine	NA	NA	NA	S	S	NA	NA
1.6 Turbo EFI engine	NA	NA	NA	NA	NA	S	NA
EEC-IV computer control	NA	NA	NA	S	S	S	NA
4-speed manual transaxle with overdrive fourth gear (2)	S	S	S	NA	NA	NA	NA
5-speed manual transaxle (2)	NA	O	O	S	S	S	NA
Maintenance-free battery	S	S	S	S	S	S	NA
Front disc/rear drum brakes (3)	S	S	S	S	S	S	NA
Rack and pinion steering	S	S	S	S	S	S	NA
Power rack and pinion steering	NA	O	O	O	O	S	NA
TR-type suspension	NA	NA	NA	S	S	NA	NA
TR turbo performance suspension	NA	NA	NA	NA	NA	S	NA
P165/80R 13 BSW steel-belted radials	S	S	S	NA	NA	NA	NA
P165/70R 365 TRX radials BSW	NA	NA	NA	S	S	NA	NA
P185/65R 365 TRX radials BSW	NA	NA	NA	NA	NA	S	NA
10-gal. fuel tank	S	NA	NA	NA	NA	NA	NA
13-gal. fuel tank	NA	S	S	S	S	S	NA
<b>EXTERIOR</b>							
Halogen headlamps	S	S	S	S	S	S	NA
Dual fog lamps	NA	NA	NA	S	S	S	NA
Bright bumpers, front and rear	S	S	S	S	NA	NA	NA
Bumper end caps, black, front and rear	S	S	NA	NA	NA	NA	NA
Deluxe bumper end caps, front and rear	NA	NA	S	S	NA	NA	NA
Deluxe bumper rub strips, front and rear	NA	NA	S	S	NA	NA	NA
Bumper guards, black, front and rear	NA	O	O	S	S	S	NA
Polycarbonate bumpers, black, with integral rub strips and argent stripes	NA	NA	NA	NA	S	S	NA
Front air dam	NA	NA	S	S	NA	NA	NA
Front lower spoiler, black	NA	NA	NA	NA	S	S	NA
Rear spoiler, black	NA	NA	NA	NA	S	S	NA
Wheel spats, black	NA	NA	NA	NA	S	S	NA
Dual accent bodyside paint stripes	NA	O	S	NA	NA	NA	NA
Unique tape stripe treatment	NA	NA	NA	S	NA	NA	NA
LH rearview mirror, black	S	S	NA	NA	NA	NA	NA
LH rearview mirror, bright	NA	NA	S	NA	NA	NA	NA
Dual remote-control racing mirrors, RH convex	NA	O	O	S	S	S	NA
Semi-styled steel wheels, 13-in. with argent wheel hub cover	S	S	NA	NA	NA	NA	NA
Full styled steel wheels	NA	NA	S	NA	NA	NA	NA
TR-type styled steel wheels with bright trim rings	NA	NA	NA	S	S	NA	NA
TR-type aluminum wheels	NA	NA	NA	O	O	S	NA
<b>INTERIOR</b>							
High-back reclining cloth bucket seats	S	S	NA	NA	NA	NA	NA
Low-back reclining cloth bucket seats	NA	O	S	S	NA	NA	NA
Sport Performance bucket seats	NA	NA	NA	NA	S	S	NA
Dual/fold down rear seat	S	S	NA	NA	NA	NA	NA
Split dual/fold down rear seat	NA	NA	S	S	S	S	NA
Deluxe belts with comfort regulators	S	S	S	S	S	S	NA
Fold-down front center armrest	NA	NA	S	S	S	S	NA
Console with integral coin tray	S	S	S	NA	NA	NA	NA
Console with graphic display warning module and integral fold-down armrest	NA	NA	O	S	S	S	NA
Digital clock with overhead console, courtesy lights and map lights	NA	O	O	S	S	S	NA
Visor vanity mirrors with covers	NA	NA	S	S	S	S	NA
Removable package tray/tonneau cover	S	S	S	S	S	S	NA
Stalk-mounted wiper/washer controls	S	S	S	S	S	S	NA
Instrumentation Group	NA	NA	O	S	S	S	NA
Tailgate "ajar" warning light (wagons)	NA	S	S	S	NA	NA	NA
AM monaural radio with dual front speakers (may be deleted for credit)	O	O	S	S	S	S	NA
Remote locking fuel door	NA	NA	S	S	S	S	NA
Remote liftgate release (hatchback only)	NA	NA	S	S	S	S	NA
Side window demisters	S	S	S	S	S	S	NA
Carpeted load floor	NA	NA	S	S	S	S	NA
Covered load floor	S	S	NA	NA	NA	NA	NA

S=Standard O=Optional NA=Not Available

## FORD ESCORT OPTIONS

ENTERTAINMENT SYSTEMS	Escort(4)	L	GL	LX	GT(5)	GT(5)	Turbo
AM monaural radio with dual front speakers	O	O	S	S	S	S	NA
AM/FM monaural radio	O	O	O	O	O	O	NA
AM/FM stereo radio	O	O	O	O	O	O	NA
AM/FM stereo radio with cassette tape player	O	O	O	O	O	O	NA
AM/FM electronic stereo search radio with cassette tape player	O	O	O	O	O	O	NA
Graphic equalizer (7-band)	NA	NA	O	O	O	O	NA
Premium sound system (6)	NA	O	O	O	O	O	NA
<b>APPEARANCE</b>							
Dual Sport mirrors, remote controlled	NA	O	O	S	S	S	NA
Two-Tone paint tape treatment (see Colors and Trims)	NA	O	O	NA	NA	NA	NA
Dual bodyside paint stripes	NA	O	S	NA	NA	NA	NA
Squire wagon option	NA	NA	O	NA	NA	NA	NA
Clearcoat paint	O	O	O	S	S	S	NA
<b>COMFORT</b>							
Air conditioning	NA	O	O	O	O	O	NA
Tinted glass	O	O	O	O	O	O	NA
Flip-up open-air roof	NA	NA	NA	O	O	O	NA
Pivoting front vent windows	NA	NA	O	O	O	O	NA
Low back reclining cloth bucket seats	NA	O	S	S	S	S	NA
<b>CONVENIENCE</b>							
Speed control	NA	O	O	O	O	NA	NA
Tilt steering wheel	NA	O	O	O	O	O	NA
Console	NA	NA	O	S	S	S	NA
Rear window defroster	O	O	O	O	O	O	NA
Rear window washer/wiper	NA	O	O	O	NA	NA	NA
Instrumentation Group (std. with diesel models)(7)	NA	NA	O	S	S	S	NA
Electronic digital clock with overhead console	NA	O	O	S	S	S	NA
Light Group (8)	NA	NA	O	O	O	O	NA
Interval windshield wipers	NA	O	O	O	O	O	NA
<b>PERFORMANCE</b>							
1.6L 2V MTX (manual transaxle)	O	S	S	NA	NA	NA	NA
1.6 liter EFI ATX (automatic transaxle)	NA	NA	NA	O	O	NA	NA
1.6 liter HO MTX (manual transaxle)	O	O	O	NA	NA	NA	NA
1.6 liter HO ATX	NA	O	O	NA	NA	NA	NA
1.6 liter "Fuel Saver" MTX (9)	S	O	O	NA	NA	NA	NA
2.0L Diesel MTX (10)	NA	O	O	NA	NA	NA	NA
2.0L Diesel "fuel saver" (11)	NA	O	NA	NA	NA	NA	NA
Heavy-duty battery (54 AH)	O	O	O	O	O	O	NA
Engine block immersion heater	NA	O	O	O	O	O	NA
California emissions system	O	O	O	O	O	O	NA
High altitude emissions system	O	O	O	O	O	O	NA
<b>POWER ASSISTS</b>							
Power front disc brakes (std. on wagons)	O	O	O	S	S	S	NA
Power steering	NA	O	O	O	O	O	NA
Power door locks	NA	NA	O	O	O	O	NA
<b>PROTECTION</b>							
Bodyside moldings	NA	O	S	S	S	S	NA
Bumper rub strips	NA	O	S	S	NA	NA	NA
Bumper guards (front and rear)	NA	O	O	S	S	S	NA
Floor mats, front	NA	NA	O	O	O	O	NA
<b>TIRES/WHEELS</b>							
P165/80R 13 WSW	NA	O	O	NA	NA	NA	NA
Bright trim rings	NA	O	NA	S	S	NA	NA
TR-type aluminum wheels	NA	NA	NA	O	O	S	NA

- 1.6L CVH HO engine standard in High Altitude areas. 1.6L CVH engine standard in California. 1.6L "FS" otherwise.
- 5-speed manual transaxle standard in High Altitude areas.
- Power disc brakes on Station Wagon, LX, GT and Turbo GT.
- Available in 2- and 4-door hatchbacks. NA with California emissions system, air conditioning, power steering.
- Available in 2-door only.
- Includes power amplifier, four upgraded speakers.
- Includes tachometer, temperature gauge and resettable trip odometer.
- Includes passenger side illuminated visor mirror, lights for ashtray, glovebox, engine compartment, cargo compartment with local switch, combination dome/map light, rear door courtesy light switch and headlamps-on warning buzzer.
- Available in 2- and 4-door hatchbacks only. NA with air conditioning, power steering, California emissions.
- Available in 2- and 4-door hatchback and Wagon models only. Includes power front disc brakes and Instrumentation Group.
- Available in 2-door hatchback only. NA with air conditioning, power steering, California emissions. Includes power front disc brakes and Instrumentation Group.

## COLOR AND TRIM CHART

Color	Interior Trim Colors				Exterior Paint Colors			
	Charcoal	Canyon Red	Regatta Blue	Sand Beige	Black	Light Oxford Grey	Midnight Canyon Red	Bright Red
Black	•	•	•	•	•	•	•	•
Light Oxford Grey	•	•	•	•	•	•	•	•
Midnight Canyon Red	•	•	•	•	•	•	•	•
Bright Red	•	•	•	•	•	•	•	•
Pastel Regatta Blue	•	•	•	•	•	•	•	•
Midnight Regatta Blue	•	•	•	•	•	•	•	•
Sand Beige	•	•	•	•	•	•	•	•
Clearcoat Paint*	•	•	•	•	•	•	•	•
Silver Clearcoat Metallic	•	•	•	•	•	•	•	•
Medium Charcoal Clearcoat Metallic	•	•	•	•	•	•	•	•
Medium Canyon Red Clearcoat Metallic	•	•	•	•	•	•	•	•
Medium Regatta Blue Clearcoat Metallic	•	•	•	•	•	•	•	•
Sand Beige Clearcoat Metallic	•	•	•	•	•	•	•	•

Note: Standard Escort is not available with Metallic paints.

## ESCORT L AND GL SERIES TWO-TONE COLOR AND TRIM CHART

Color	Interior Trim Colors				Exterior Paint Colors			
	Charcoal	Canyon Red	Regatta Blue	Sand Beige	Black/Charcoal Clearcoat Metallic	Silver Metallic Clearcoat/Medium Charcoal Clearcoat Metallic	Pastel Regatta Blue/Medium Regatta Blue Clearcoat Metallic	Sand Beige/Medium Sand Beige
Black	•	•	•	•	•	•	•	•
Light Oxford Grey	•	•	•	•	•	•	•	•
Midnight Canyon Red	•	•	•	•	•	•	•	•
Bright Red	•	•	•	•	•	•	•	•
Pastel Regatta Blue	•	•	•	•	•	•	•	•
Midnight Regatta Blue	•	•	•	•	•	•	•	•
Sand Beige	•	•	•	•	•	•	•	•
Medium Sand Beige	•	•	•	•	•	•	•	•
Oxford White	•	•	•	•	•	•	•	•
Silver Clearcoat Metallic	•	•	•	•	•	•	•	•

NOTE: Two-Tone color choices are reversible. \*Clearcoat Paint is a special finish achieved by applying two coats of highly pigmented low gloss polyester enamel over the primer. Then final "clear" coats of acrylic enamel are applied for a deep, glossy finish.

## ESCORT GT/TURBO GT COLOR AND TRIM CHART

Color	Interior Trim Colors		Exterior Paint Colors	
	Charcoal	Sand Beige	Black	Bright Red
Black	•	•	•	•
Light Oxford Grey	•	•	•	•
Midnight Canyon Red	•	•	•	•
Bright Red	•	•	•	•
Pastel Regatta Blue	•	•	•	•
Midnight Regatta Blue	•	•	•	•
Sand Beige	•	•	•	•
Clearcoat Paint*	•	•	•	•
Silver Clearcoat Metallic	•	•	•	•
Medium Charcoal Clearcoat Metallic	•	•	•	

# Safety Features

## A commitment to safety

Safety, like quality, begins as an attitude, a way of thinking that's fundamental in shaping a vehicle's structure and components from the drawing board to assembly.

## Occupant safety

Ford commits enormous resources every year to the development and testing of all car lines and their occupant protection features.

Body structures are carefully designed from the start with passenger safety as a primary concern. After they are validated for theoretical soundness, structures are assembled into prototype vehicles and subjected to exhaustive crash testing.

## Operating safety

This term applies to a vehicle's ability, with the aid of the driver, to avoid an accident.

Ford cars are engineered to do their part — provide suspension and steering systems designed for control, as well as a brake system that is designed to provide fast stopping action and fade resistance.

Of course, it's up to the driver to make the best use of the vehicle's accident-avoidance equipment. This involves driving defensively, reacting in time, and such seemingly small things as properly regulating the ventilation system (to help the driver stay alert).

## 5-mile-an-hour bumpers

Bumpers on Ford Escort are designed to protect lamps, cooling system, exhaust and other body components in the event of a minor impact. While some manufacturers have replaced the 5-mile-an-hour bumper system with a 2<sup>1</sup>/<sub>2</sub>-mile-an-hour system, Ford offers you the protection of 5-mile-an-hour bumpers, front and rear.

## Get it together — buckle up.

Ford Motor Company strongly encourages all passengers to use their safety belts.

In all Ford cars, outboard front seat lap and shoulder belts have automatic retractors and comfort regulators. Outboard rear seat positions also have lap belts with retractors.



Ford urges the use of child and infant restraints, even in states where they are not required by law. Ford's easy-to-install Tot-Guard (for children 20 to 50 pounds) and Infant Carrier (for children up to 20 pounds) are available at all Ford Dealers. If a child restraint requires a top-tether, Ford cars provide for attachment of an anchor at each rear outboard seating position.

## Ford Escort Lifeguard Design Safety Features

### Vehicle operation

Safety rim wheels and load-rated tires  
 Split diagonal service hydraulic brake system with warning light  
 Corrosion-resistant brake lines  
 Turn indicator lever with lane-changing signal feature  
 Hazard warning flasher  
 Backup lights  
 Parking lights (which also serve as side marker lights) coupled with headlamps  
 Two-speed windshield wipers  
 Windshield washers  
 Outside rearview mirror, driver's side  
 Glare-reduced instrument panel, windshield wiper arms, and windshield pillars  
 Uniform transmission shift quadrant with safety starting switch (on all cars equipped with automatic transaxle)  
 Continuously variable control illumination intensity (instrument cluster lighting)  
 Safety hood latch system  
 Function-rated windshield defroster system

### Occupant protection

Safety-designed front end structure  
 Safety-designed roof structure  
 Steel guard rails in side doors  
 Double yoke safety door latches and safety hinges  
 Integral lap and shoulder belts with automatic retractors for occupants of front seats  
 Positive seat belt fastening reminder warning light and buzzer for driver's seat  
 Lap belts with retractors for rear seat occupants  
 Energy-absorbing steering column and steering wheel system  
 Energy-absorbing armrests and safety-designed door handles  
 Energy-absorbing instrument panel with padding for right front passenger  
 Energy-absorbing sun visors  
 Energy-absorbing front seat back tops with padding  
 Self-locking seat back latches (2-door vehicles)  
 Head restraints or high back seats for front outboard occupants  
 Safety glove box latch  
 Inside yieldaway rearview mirror  
 Impact-absorbing laminated safety glass windshield  
 Flame-resistant interior materials  
 Safety-designed coat hooks  
 Safety-designed radio control knobs and push buttons

### Anti-theft

Locking steering column with key warning buzzer reminder and push button key release  
 Visible vehicle identification number  
 Single key with anti-theft design for door entry and ignition

### Damage resistance

Impact resistant front and rear bumper systems

# Owner Information

## Measurements

	2-Door/4-Door	Wagon
Wheelbase	94.2"	94.2"
Length	163.9"	165.0"
Height	53.3"	53.3"
Width	65.9"	65.9"
Front tread	54.7"	54.7"
Rear tread	56.0"	56.0"
Cargo capacity (cu. ft.)	17/37	29/58
Curb weight**	2,074	2,139
Passengers	4	4

\*First figure, rear seat up. Second figure, rear seat down.  
 \*\*Escort L 2-Door and Wagon with 4-speed manual transaxle. Other models vary slightly.



As part of Ford Motor Company's commitment to your total satisfaction, participating Ford Dealers offer the Free Lifetime Service Guarantee. They stand behind their work, in writing, for as long as you own your car. This guarantee covers virtually every repair you pay for after your new vehicle warranty expires. Now when you pay for a covered repair once, you never have to pay for the same repair again. Ever. The dealer who did the work will fix it free. Free parts. Free labor.

While it doesn't cover routine maintenance parts, belts, hoses, sheet metal or upholstery, this limited warranty does cover thousands of parts in normal use.

No other car company's dealers, foreign or domestic, offer this kind of security. Nobody.

See your participating Ford Dealer for details.



Ford Motor Company's optional Extended Service Plan covers major components on new Ford cars and light trucks for longer than the vehicle's basic warranty. The cost is so moderate for the protection you get that it could pay for itself the first time you need it. Your Ford Dealer will be happy to detail the plan for you. Available on all cars and most light trucks, it is honored by more than 6,100 Ford and Lincoln-Mercury dealers nationwide and in Canada.

## Motorcraft QUALITY REPLACEMENT PARTS FROM FORD

Genuine Ford and Motorcraft original equipment replacement parts are precision engineered and manufactured to Ford specifications to deliver top-level performance in all Ford-built cars and trucks. The Ford and Motorcraft brand names are your best assurance of quality and long-term satisfaction because these replacement parts meet the same high standards as those installed in production, and at Ford, "Quality is Job 1."

## Scheduled maintenance

Ford wants to reduce the frequency and cost of scheduled maintenance on its cars to an absolute minimum. Here are some examples of scheduled maintenance intervals for the 1985 Ford Escort. For complete maintenance recommendations, refer to the Escort Owner Guide.

Engine oil	each 7,500 miles
Diesel	each 7,500 miles
Turbo	each 5,000 miles
Spark plug change non-turbo	each 30,000 miles
Turbo	each 15,000 miles
Air filter replacement	each 30,000 miles
Engine coolant replacement	each 30,000 miles or 3 years
Diesel	each 30,000 miles

## The commitment to quality by Ford and its dealers can save you money on repairs, too.

In addition to the Lifetime Service Guarantee, the Extended Service Plan and Ford and Motorcraft original equipment parts already described, Ford and Ford Dealers are working in other ways to save you money on repairs and help ensure your satisfaction.

## Nationwide dealer network ready to assist you

Should your Ford car or truck need repair while you're traveling or away from home, the nearest servicing dealer can be located simply by calling one of the toll-free numbers listed under "Ford-paid repair programs."

## Specialized tools and equipment

The latest in diagnostic and service equipment designed especially for use in the repair of Ford Motor Company products is available. This equipment helps the technician make the repair properly so you won't have to come back a second time.

## Continued service technician training

Dealership technicians are continuously updated on the latest techniques and procedures to help them keep your Ford car or truck running at its best.

## Ford-paid repair programs after the warranty period

Sometimes Ford offers adjustment programs to pay all or part of the cost of certain repairs. These programs are intended to assist owners and are in addition to the warranty or to required recalls. Ask Ford or your dealer about such programs relating to your Ford or Lincoln-Mercury vehicle.

To get copies of any adjustment program for your vehicle or the vehicle of interest to you: Call Ford toll-free at 1-800-241-3673. Alaska and Hawaii call 1-800-241-3711 and in Georgia call 1-800-282-0959.

Or write Ford at:

Ford Customer Information System  
 P.O. Box 95427  
 Atlanta, Georgia 30347

We'll need your name and address; year, make and model vehicle, as well as engine size; and whether you have a manual or automatic transmission.

## Technical service bulletins

All vehicles need repairs during their lifetime. Sometimes Ford issues technical service bulletins (TSBs) and easy-to-read explanations describing unusual engine or transmission conditions which may lead to costly repairs, the recommended repairs, and new repair procedures. Often a repair now can prevent a more serious repair later. Ask Ford or your dealer for any such TSBs and explanations relating to your Ford or Lincoln-Mercury vehicle.

To get copies of these technical service bulletins and explanations for your vehicle or the vehicle of interest to you: Call Ford toll-free at 1-800-241-3673. Alaska and Hawaii call 1-800-241-3711 and in Georgia call 1-800-282-0959.

Or write Ford at:

Ford Customer Information System  
 P.O. Box 95427  
 Atlanta, Georgia 30347

We'll need your name and address; year, make and model vehicle, as well as engine size; and whether you have a manual or automatic transmission.

## Options availability

Options shown or described here and elsewhere in this catalog are available at extra cost and may be offered only in combination with other options or subject to additional ordering requirements or limitations. Your Ford Dealer has the latest information.

## Product changes

Ford Division reserves the right to change product specifications at any time without incurring obligations.

## "Ask your Ford Dealer"

Following publication of this catalog, certain changes in standard equipment, options, prices and the like, or product delays, may have occurred which would not be included in these pages. Your Ford Dealer is your best source for up-to-date information.

Have you driven  
a Ford...lately?



FORD ESCORT

